

Softlight

Comfortable light, bright spaces



EXCELLENT LIGHTING, SAVING ENERGY



Comfortable light, bright spaces

Comfortable light

ETAP's softlight luminaires shield the light source and mainly allow the light into the space through secondary optics, which prevents direct view and glare. Especially in LEDs this contributes significantly to visual comfort.

Bright spaces

Softlights create clearly lit spaces: they evenly illuminate walls and ceilings – no shadows, dark spots or outline between lit and unlit areas. The soft light is discreetly present in the space and provides your interior with character.

Wide field of application

Softlights provide, comfortable lighting in offices, conference rooms, stores, care homes, hospitals, schools, etc. They contribute to a pleasant and warm atmosphere in workspaces, reception rooms, corridors and stairwells.

The extensive ETAP range ensures that you can apply the softlight principle everywhere in your buildings. You can choose from recessed, surface-mounted and wall-mounted versions, several shapes (square or linear), dimensions and light sources (fluorescent or LED).



Comfort and output reconciled

ETAP softlights combine the best of both worlds. They obviously offer the natural lighting comfort for which softlights are known. But at the same time, they achieve the impossible with their sophisticated photometrics in terms of energy-efficiency.

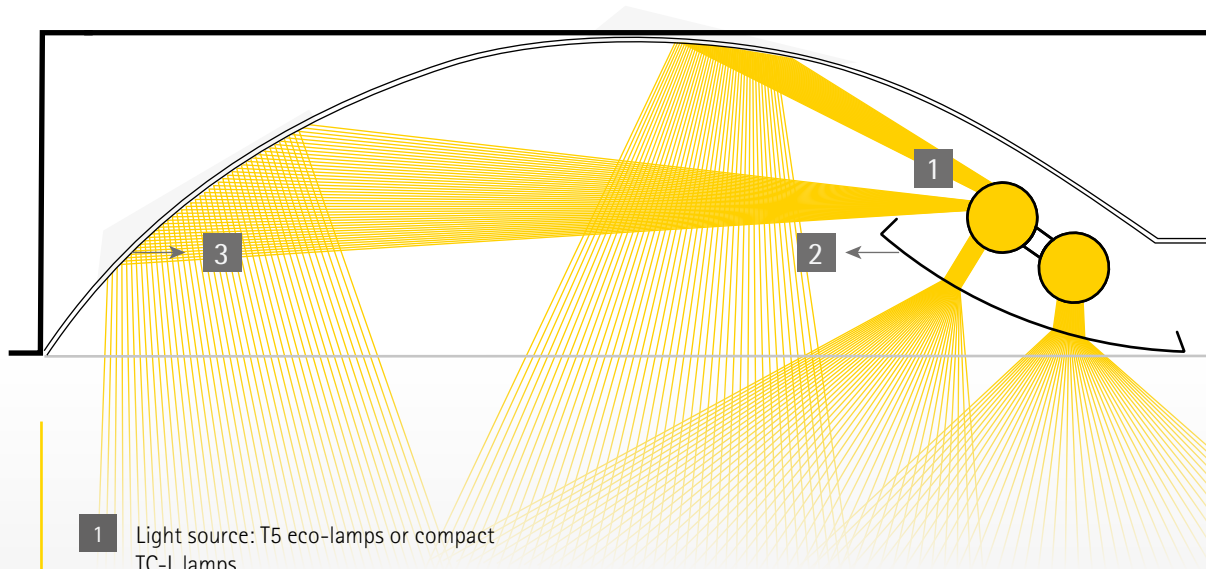

FLUO

- 1 Light source: T5 eco-lamps or compact TC-L lamps.
- 2 Primary optics: perforated or diffuse shielding of the light source.
- 3 Secondary optics: side reflectors with highly reflective lacquer. The arched shape of the top reflector was designed to maximise reflection and to distribute light evenly in the space.

Primary optics



- Perforated shielding
- Lacquered sheet steel



- Diffuse shielding
- Polymethylmethacrylate (PMMA) – satisfies glow wire test at 650°C.
 - Polycarbonate (PC) – satisfies glow wire test at 960°.

Application: office with US01J1/413HFW

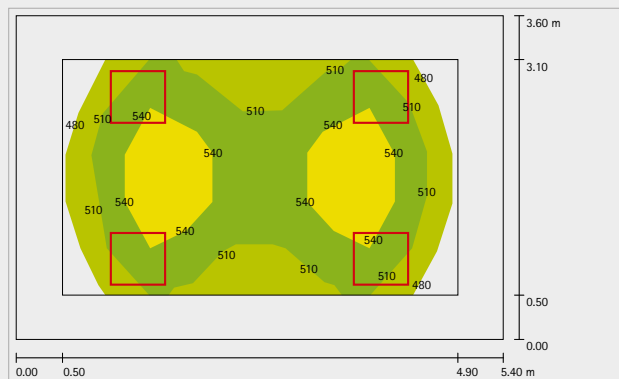

- Average illuminance on the work surface: 522 lx
- Specific power: 2,13W/m²/100 lx
- Maintenance factor: 0,85
- UGR: 25

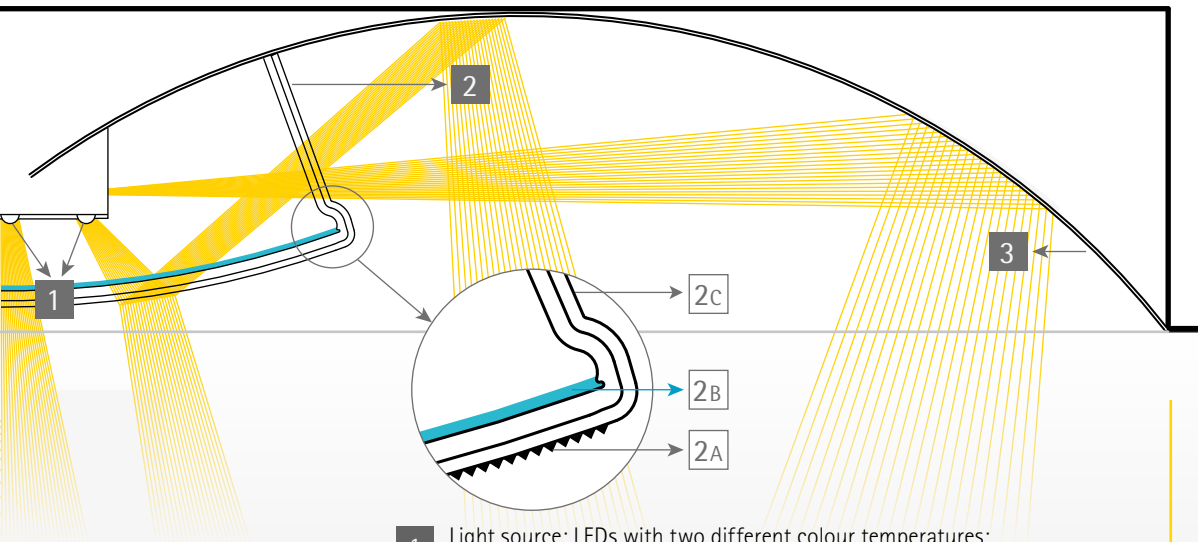

- 1** Light source: LEDs with two different colour temperatures: 3000K (warm white) or 4000K (cold white).
- 2** Primary optics: shielding of the light source
 - 2A** Microprism structure for low glare (UGR < 19 for offices)
 - 2B** Diffuser foil for good illumination of the optics, without the LEDs being visible
 - 2C** Diffuse, transparent side
- 3** Secondary optics: side reflectors with highly reflective lacquer

LED

Primary optics

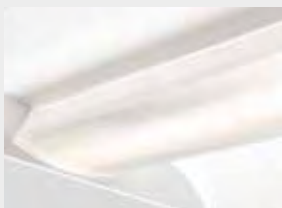

- Diffuse shielding with microprism structure and MesoOptics™ foil
- Polymethylmethacrylate (PMMA) – satisfies glow wire test at 650°C.
 - Polycarbonate (PC) – satisfies glow wire test at 960°.

The combination of the microprism structure and MesoOptics™ foil contribute to low glare (UGR < 19), which makes them suitable for office lighting. A high-output version with UGR < 22 is available for applications that require high lumen packages. The high luminaire efficiency and maintenance factor (97% LLMF after 50.000 burning hours) result in never-before-seen performance for softlights.

Application: office with US01_LEDN35S

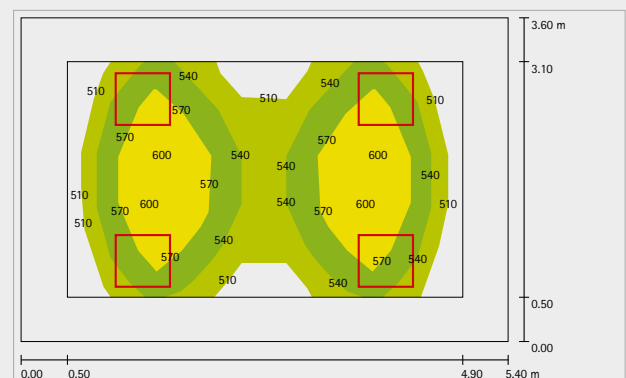

- Average illuminance on the work surface: 552 lx
- Specific power: 1,23W/m²/100 lx
- Maintenance factor: 0,87
- UGR: 19

A softlight for every application

US

Recessed







Easy installation in any ceiling.

The US recessed series consists of square (600 x 600 mm) or linear (300 x 1200 mm) luminaires and comes in three mounting depths: 120, 80 and 40 mm. The luminaires were designed for easy installation in suspended ceilings. An adjusted mounting frame is available for plasterboard ceilings.

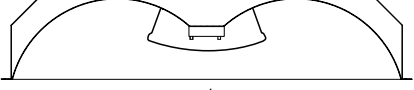
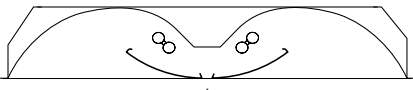
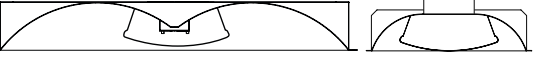

The US recessed luminaires can be easily installed in a suspended ceiling by placing them on the profiles.

Softlight

	LED	FLUO
US01 mounting depth 120 mm	 M600/M625	 M600/M625
US21 mounting depth 80 mm*	 M600/M625 M300*	 M600 M300
US11 mounting depth 40 mm	 M600/M625	 M600

* US21 with LED, M300: mounting depth 100 mm



A softlight for every application

RS

Surface-mounted



For ceilings that do not allow for recessing, ETAP offers a surface-mounted version of its softlight luminaires, which combines the optics of the recessed version with a floating frame. Installation is a cinch thanks to a supplied bracket on which the luminaire is mounted. Surface-mounted luminaires are only available in square version.

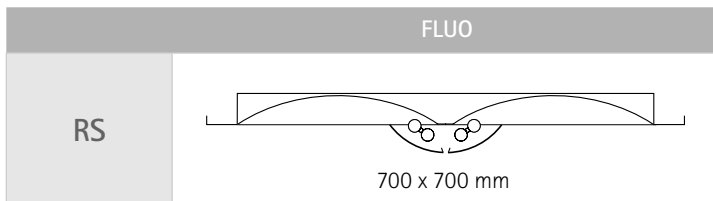

WS

Wall luminaires

With the WS wall luminaires you can also extend the softlight style to your accent lighting. The wall luminaires illuminate the wall on which they are mounted, which makes the latter act as secondary optics. The luminaires are available in three different lengths – 310, 505 and 1250 mm – for a fitting solution for every wall. Wall luminaires are only available with perforated lamp shielding.





Flexibility feature

In ETAP's softlight luminaires general lighting can be flexibly combined with various other building technologies.

Integrated light control

With the ETAP light control systems you will keep your energy bill under control. Our softlight luminaires are available with integrated ELS daylight control or EMD multidetector, which combines daylight control, motion detection and infrared remote control.



US recessed luminaire with discreet ELS sensor for daylight control.

Emergency units

The recessed luminaires in our softlight range can be fitted with an integrated emergency unit.

Air extraction

The fluorescent versions of our softlight luminaires can be provided with vents for air extraction through the ceiling.

Easy maintenance

ETAP's softlight luminaires are easy to maintain.

The lamp shielding on the fluorescent version (photo right) can be easily opened to clean the optics or replace the lamps. In the LED version (photo left) the optics form a single seamless unit, in which the LEDs are safely sealed and which provides full protection against dust and insects.





SOFTLIGHT

- Comfortable and glare-free lighting
- Advanced light technology for maximum output
- Extensive range for a wide range of applications
- Easy installation and low maintenance
- Efficient protection against dirt and insects



ETAP NV • 7 Progress Business Centre • Whittle Park Way • Slough • Berkshire SL1 6DQ
Tel. +44 (0)1628 559 650 • Fax +44 (0)1628 559 012 • enquiries@etaplighting.com

ETAP Export Department • Antwerpsesteenweg 130 • 2390 Malle • Belgium
Tel. +32 (0)3 310 02 11 • Fax +32 (0)3 311 61 42 • export@etaplighting.com

ETAP U.A.E. • Energy Et Environment Park • Nucleotide Lab, 2nd floor, Office EO 01, PO BOX 345014, Al Barsha • Dubai, UAE
Tel. +971 (0)4 434 7364 • Fax +971 (0)4 437 0378 • export@etaplighting.com

www.etaplighting.com